

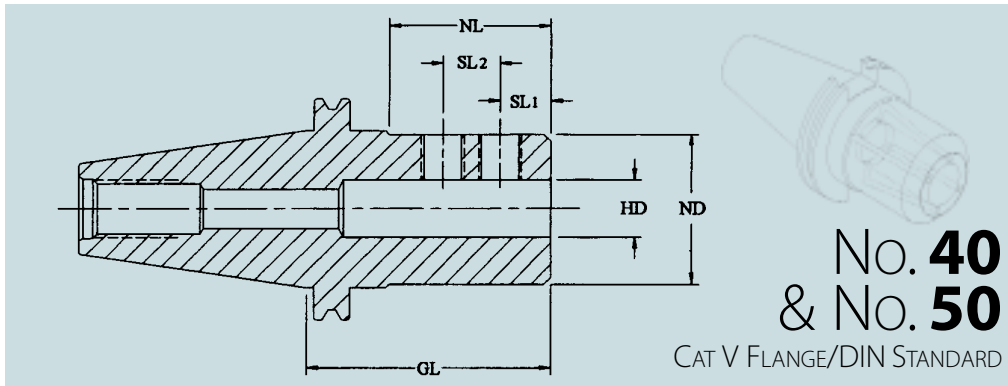

FlushCut™

COOLANT-THROUGH Milling Adapter



PATENTED INTERNAL PASSAGEWAYS, DELIVER HIGH-PRESSURE COOLANT TO THE CUTTING TOOL AND WORKPIECE WITH SUFFICIENT VELOCITY TO REMOVE CHIPS.

- INCREASE SURFACE SPEEDS
- REDUCE THERMAL DISTORTION
- INCREASE FEED RATES
- IMPROVE OPERATOR SAFETY
- INCREASE TOOL LIFE
- FAIL-SAFE OPERATION IN UNATTENDED PRODUCTION AREAS
- INCREASE DEPTH OF CUT
- REDUCE CUTTER OVERHANG
- LOWER CUTTER & INSERT COSTS

No. 40							No. 50						
TOOL NO.	HD HOLE DIAMETER	GL GAGE LENGTH	ND NOSE DIAMETER	NL NOSE LENGTH	S.L. ¹	S.L. ²	TOOL NO.	HD HOLE DIAMETER	GL GAGE LENGTH	ND NOSE DIAMETER	NL NOSE LENGTH	S.L. ¹	S.L. ²
STUB LENGTH							STUB LENGTH						
40CVTS0625SS	.625	2.375	1.750	1.625	.938	—	50CVTS0875SS	.875	3.000	2.500	2.250	1.125	—
40CVTS0750SS	.750	2.375	1.750	1.625	1.000	—	50CVTS1000SS	1.000	3.000	2.500	2.250	1.125	—
40CVTS0875SS*	.875	3.000	2.500	2.250	1.125	—	50CVTS1250SS	1.250	3.000	2.500	2.250	1.125	—
40CVTS1000SS*	1.000	3.000	2.500	2.250	1.125	—	50CVTS2000SS*	2.000	4.000	3.875	3.250	1.375	1.500
40CVTS1250SS*	1.250	3.000	2.500	2.250	1.125	—	*Note: Does not conform to ANSI B5.50 (No under-cut next to flange.) Consult Tool Fabrication Corporation for details.						
STANDARD LENGTH							STANDARD LENGTH						
40CVTS0250SL	.250	2.750	1.250	1.125	.625	—	50CVTS0375SL	.375	3.000	1.500	1.500	.750	—
40CVTS0375SL	.375	3.000	1.500	1.500	.750	—	50CVTS0500SL	.500	3.000	1.500	1.500	.875	—
40CVTS0500SL	.500	3.000	1.500	1.500	.875	—	50CVTS0625SL	.625	3.375	1.750	2.625	.938	—
40CVTS0625SL	.625	3.375	1.750	2.625	.938	—	50CVTS0750SL	.750	3.750	1.750	2.625	1.000	—
40CVTS0750SL	.750	3.375	1.750	2.625	1.000	—	50CVTS0875SL	.875	4.000	2.500	3.250	1.125	1.000
40CVTS0875SL	.875	4.000	2.500	3.250	1.125	1.000	50CVTS1000SL	1.000	4.000	2.500	3.250	1.125	1.000
40CVTS1000SL	1.000	4.000	2.500	3.250	1.125	1.000	50CVTS1250SL	1.250	4.750	3.375	3.250	1.250	1.000
40CVTS1250SL	1.250	4.000	2.500	3.250	1.125	1.000	50CVTS2000SL	2.000	5.625	3.875	4.875	1.375	1.500
LONG LENGTH							LONG LENGTH						
40CVTS0250LS	.250	4.750	1.250	3.125	.625	—	50CVTS0375LS	.375	5.000	1.500	3.500	.750	—
40CVTS0375LS	.375	5.000	1.500	3.500	.750	—	50CVTS0500LS	.500	5.000	1.500	3.500	.875	—
40CVTS0500LS	.500	5.000	1.500	3.500	.875	—	50CVTS0625LS	.625	5.375	1.750	4.625	.938	—
40CVTS0625LS	.625	5.375	1.750	4.625	.938	—	50CVTS0750LS	.750	5.375	1.750	4.625	1.000	—
40CVTS0750LS	.750	5.375	1.750	4.625	1.000	—	50CVTS0875LS	.875	6.000	2.500	5.250	1.125	1.000
40CVTS0875LS	.875	6.000	2.500	5.250	1.125	1.000	50CVTS1000LS	1.000	6.000	2.500	5.250	1.125	1.000
40CVTS1000LS	1.000	6.000	2.500	5.250	1.125	1.000	50CVTS1250LS	1.250	6.000	2.500	5.250	1.125	1.000
40CVTS1250LS	1.250	6.000	2.500	5.250	1.125	1.000	50CVTS2000LS	2.000	7.625	3.875	6.875	1.375	1.500
EXTRA-LONG LENGTH							EXTRA-LONG LENGTH						
50CVTS0375EL	.375	7.000	1.500	5.500	.750	—	50CVTS0500EL	.500	7.000	1.500	5.500	.875	—
50CVTS0625EL	.625	7.375	1.750	6.625	.938	—	50CVTS0750EL	.750	7.375	1.750	6.625	1.000	—
50CVTS0875EL	.875	8.000	2.500	7.250	1.125	1.000	50CVTS1000EL	1.000	8.000	2.500	7.250	1.125	1.000
50CVTS1250EL	1.250	8.000	2.500	7.250	1.125	1.000	50CVTS2000EL	2.000	8.000	2.500	7.250	1.125	1.000

Some Flush-Cuts™ may be a "non-stock" standard.

Flush-Cut™ Adapters are available in a wide variety of shanks, sizes and gage lengths. Consult Tool Fab or your distributor about Flush-Cut™ Products and your specific milling application.